



Example: KLR Line

Medical Industry

L-LINE SOLUTIONS **KLR LINE**



WRF

RF Welding
Technology

The L-shaped line is designed for manufacturing infusion bags and other PVC or non-PVC products, suiting special conditions.

The L-line is available in radio-frequency welding technology. Up to 6 films are wound off the reel holders and run through the machine in parallel. The L-line is mostly built for tube films.

Individual component feeding is possible with smart systems.

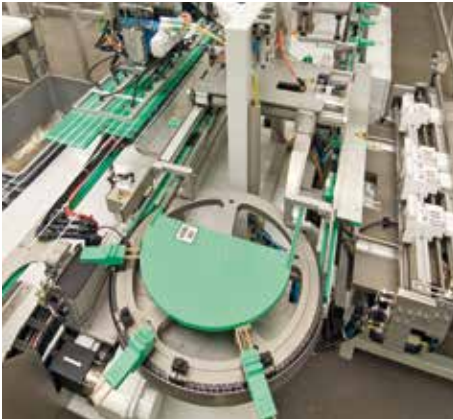

Components loading on mandrel chain

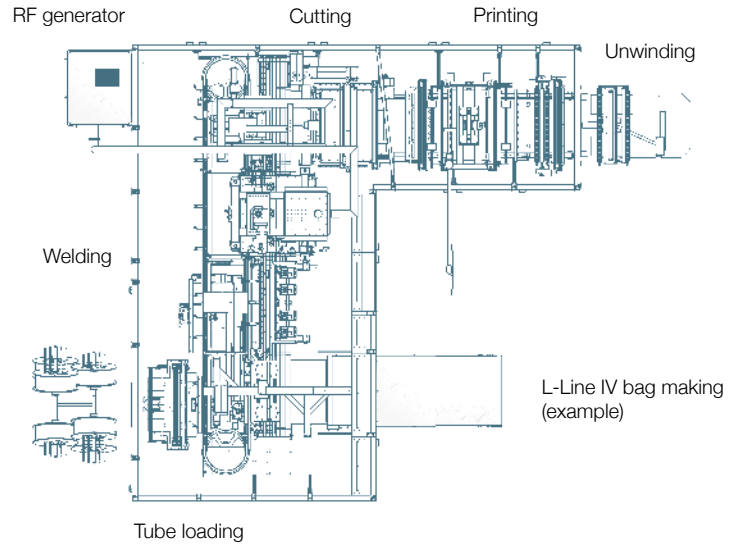

L-Line Solutions KLR Line



Reels unwinding

Main benefits at a glance

- Modular** design
- Highest flexibility** for product designs
- Optimized machine footprint**, which leads to a higher output per m²
- Reject part management** based on monitored parameters
- Self-diagnosis-system**
- Quick product changeover** due to quick clamping devices
- The welding stations are **driven by servomotors** including load cells, which guarantee a
 - higher precision and repeatability of production steps
 - lower air consumption
- The component-feed is done by **automatic vibratory feeder bowls** to a mandrel chain
- Tube unwinding**

Technical data	KLR 94 Highliner (example)	KLR 94 Highliner (example)	KLR 94 Highliner (example)
Welding technology	radio-frequency	radio-frequency	radio-frequency
Generator power	12 kW	2 x 12 kW	2 x 12 kW
Maximum pressing force	40 kN	40 kN	40 kN
Maximum press stroke	100 mm	100 mm	100 mm
Useful welding area	900 x 475 mm	900 x 475 mm	900 x 475 mm
Maximum film width	290 mm	140–180 mm	80–120 mm
Dimensions (L x W x H) approx.	9.000 x 8.000 x 2.700 mm	9.500 x 8.000 x 2.800 mm	12.900 x 8.000 x 2.700 mm
Machine weight approx.	15.000 kg	23.000 kg	24.000 kg
Power rating	60 kVA	86 kVA	86 kVA
Compressed air consumption	1.400 NI/min	1.500 NI/min	1.600 NI/min
Cooling water consumption	0,36 m ³ /h	0,36 m ³ /h	0,36 m ³ /h
Power consumption	10 kWh	27 kWh	27 kWh
Operation	3-up	4-up	6-up
Nominal output (500ml bag) approx.	1.800 bags/hour	2.400 bags/hour	3.600 bags/hour